

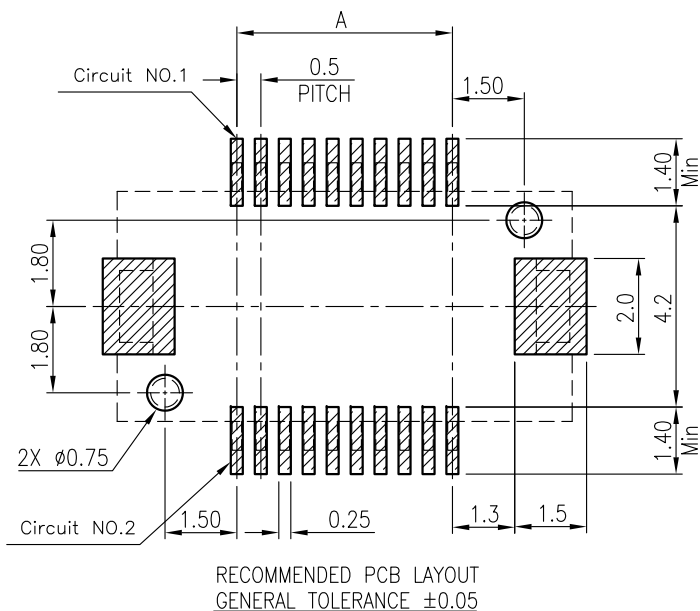

- NOTES:
- MATERIAL:
    - HOUSING: THERMOPLASTIC, HIGH TEMP., UL94V-0;
    - CONTACT: COPPER ALLOY
    - FITTING NAIL: COPPER ALLOY
  - FINISH:
    - CONTACT: PER ACES P/N PLATING CODE.
    - FITTING NAIL: PER ACES P/N PLATING CODE.
  - REFLOW SOLDER CAPABLE TO 260°C PER ACES SPEC.
  - SPEC. PLS. REFER TO PS-50019-XXXX-XXX
  - PACKAGE PLS. REFER TO 88079-XXXXA-TRP OR 88079-XXXXW-TRP
  - PART NUMBER

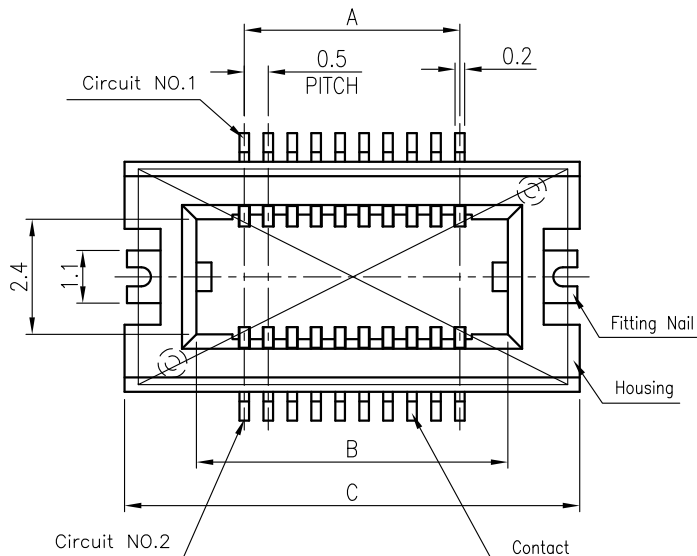

50019-XXX X X-XXX

NO OF CKT

XXX	Housing Color	Halogen Free	Packing
001	Black	HF	88079-XXXXA-TRP
W01	Black	HF	88079-XXXXW-TRP

PLATING  
1: GOLD FLASH OVER ALL  
N: MATT TIN

PACKING  
0:TAPE REEL  
1:TUBE PACKAGE  
4:TAPE REEL WITH MYLAR  
5:TUBE PACKAGE WITH MYLAR  
7:TAPE REEL WITH COVER  
8:TUBE PACKAGE WITH COVER

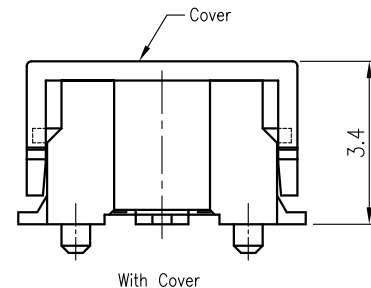
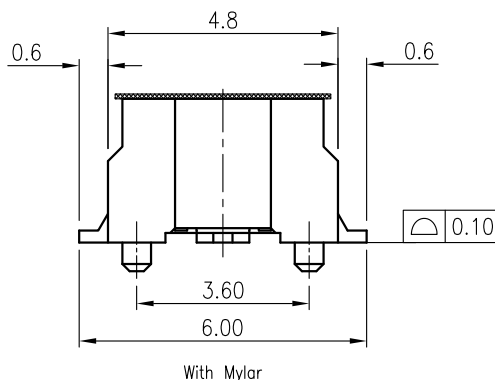
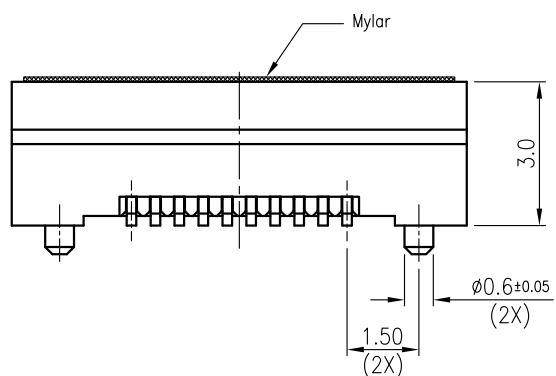

CKT	Dim A	Dim B	Dim C	MYLAR
10	2.0	4.0	7.0	W3T12-88079
16	3.5	5.5	8.5	W6T12-88079
20	4.5	6.5	9.5	W6T12-88079
24	5.5	7.5	10.5	W6T12-88079
26	6.0	8.0	11.0	W6T12-88079
30	7.0	9.0	12.0	W6T12-88079
40	9.5	11.5	14.5	WAT12-88079
50	12.0	14.0	17.0	WAT12-88079
60	14.5	16.5	19.5	WFT12-88079
70	17.0	19.0	22.0	WFT12-88079
80	19.5	21.5	24.5	WFT12-88079
100	24.5	26.5	29.5	WFT12-88079
120	29.5	31.5	34.5	WFT12-88079

一般公差 <b>TOLERANCES</b> X ±0.5 .XX ±0.15 X ±0.25 .XXX ±0.1 ANGLES ±2°		<b>宏致電子股份有限公司</b> <b>Aces Electronic Co.,Ltd.</b>	
檢驗尺寸標示 SYMBOLS (M) (S) INDICATE CLASSIFICATION DIMENSION (C) MARK IS CRITICAL DIM. (M) MARK IS MAJOR DIM.	品名 (TITLE) <b>0.5mm BTB PLUG</b> <b>SMT D/R S/T TYPE</b>	製圖 (DR) 11/01/06 yangwu 審核 (CHKD) <b>CARL</b>	5
表面處理 (FINISH)	圖號 (DWG.NO) <b>50019-XXXX-XXX</b>	核准 (APPD) <b>JASON</b>	
比例 (SCALE) 6:1	單位 (UNITS) mm	張數 (SHEET) 1 OF 1	SIZE A4
		REV C	